

**CLUTCH PRESSURE CONTROL SOLENOID AND VALVE OPERATION "OFF"**

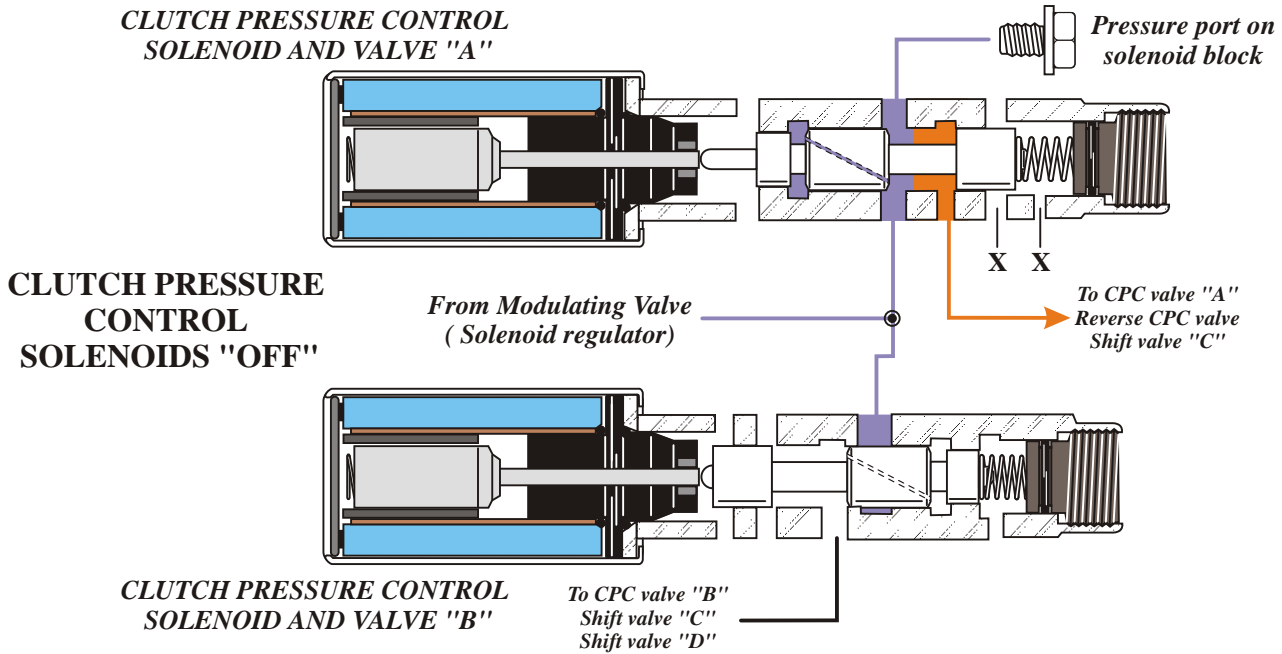

*Clutch Pressure Control Solenoid and Valve "A" supply modulating pressure to CPC valve "A", Reverse CPC valve and Shift valve "C" when "OFF."*

*Clutch Pressure Control Solenoid and Valve "B" shut off the supply of modulating pressure to CPC valve "B", Shift valve "C" and Shift Valve "D" when "OFF."*

**CLUTCH PRESSURE CONTROL SOLENOID AND VALVE OPERATION "ON"**

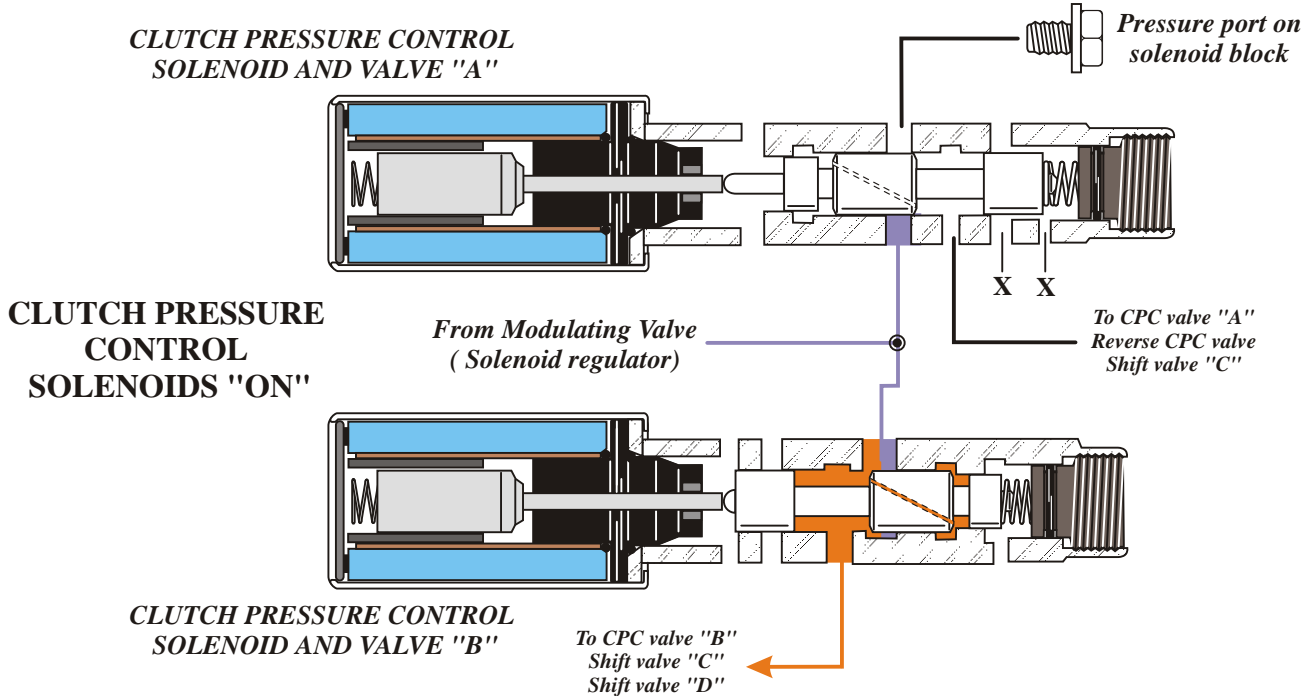

*Clutch Pressure Control Solenoid and Valve "A" shut off the supply of modulating pressure to CPC valve "A", Reverse CPC valve and Shift valve "C" when "ON."*

*Clutch Pressure Control Solenoid and Valve "B" supply modulating pressure to CPC valve "B", Shift valve "C" and Shift Valve "D" when "ON."*

Copyright © 2002 ATSG

Figure 8

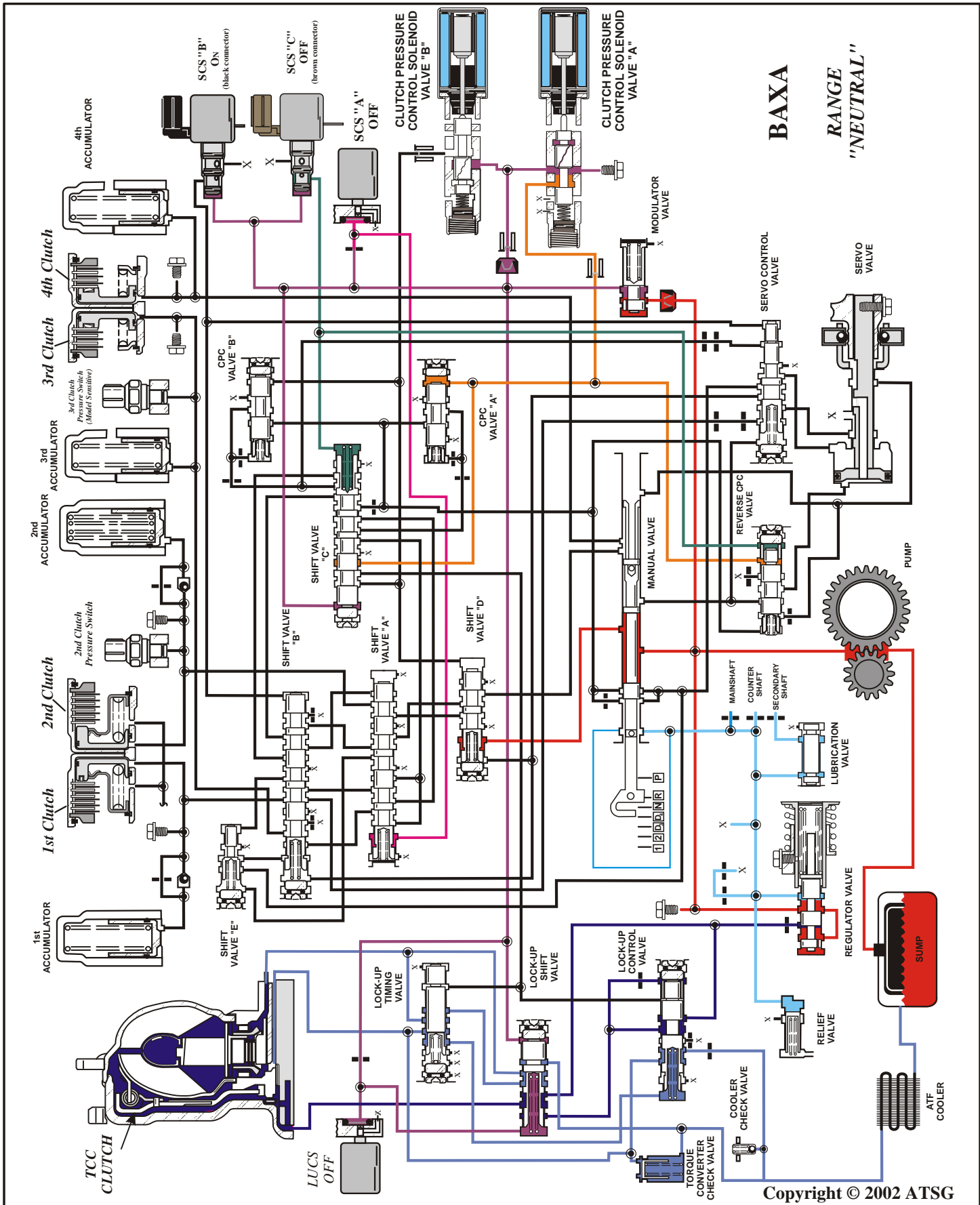

Copyright © 2002 ATSG

Figure 13